



HUB-VM102

Operating Instructions

Valid SIINEOS version: 2.9.0 and above
Document version 1.2 | Publication date:
04. May 2026

Table of Contents

- Legal information 3**
- 1. General information 5**
 - 1.1. Scope of delivery 5
 - 1.2. Recommended accessories 5
 - 1.3. Other applicable documents 5
 - 1.4. Open source 5
 - 1.5. Disposal 5
- 2. General product information 6**
 - 2.1. Intended use 6
 - 2.2. Hardware – design and interfaces 7
 - 2.2.1. Power supply 8
 - 2.2.2. Pin assignment of the CH1 and CH2 interfaces 8
 - 2.2.3. LED display 9
 - 2.2.4. LED display on the ETH socket 10
- 3. Assembly 11**
 - 3.1. Mounting the device on the DIN rail 11
 - 3.2. Installation on a backplane bus 12
 - 3.3. Dismantling the device 12
- 4. Installation 13**
 - 4.1. Connecting a power-supply unit 13
 - 4.2. Establishing a supply voltage via backplane bus 13
 - 4.3. Connecting vibration sensors 14
- 5. Further steps in the master gateway’s SIINEOS 15**
 - 5.1. Establishing communication with the HUB-VM102 via a network 15
 - 5.2. Establishing communication with the HUB-VM102 via a backplane bus 19
- 6. Typical use cases in practice 21**
 - 6.1. Communication via a network and data transfer to a master gateway or third-party system 21
 - 6.2. Communication via network and data transfer to PLC or PC 22
 - 6.3. Communication via backplane bus and data transfer to a master gateway or third-party system 23
- 7. Technical data 24**
 - 7.1. Specification of the CH1 and CH2 interface 25
 - 7.2. Backplane bus specification 26

Legal information

Safety information

This documentation contains information that you must observe for your personal safety and to prevent material damage. Read the safety information carefully and always keep this documentation within easy reach.

The safety information is presented in descending order of hazard level as follows:

**DANGER**

Indicates an immediate hazard to humans. Failure to comply will lead to irreversible injuries or death.

**WARNING**

Indicates an identifiable hazard to humans. Failure to comply may lead to irreversible injuries or death.

**CAUTION**

Indicates an identifiable hazard to humans or potential material damage. Failure to comply may lead to reversible injuries or material damage.

**ATTENTION**

This gives you information that may lead to material damage if not complied with.

**NOTE**

A note gives you useful information on specific actions and issues.

**TIP**

A tip gives you tips, tricks or recommendations from in.hub that have proven to be helpful in handling the products.

Qualified personnel

The product associated with this documentation may only be handled by personnel qualified for the respective task. The device may only be installed, commissioned and operated in compliance with the associated documentation and the safety information contained therein.

Based on their training and experience, qualified personnel are able to recognize risks and avoid potential hazards when handling these products.

Knowledge of PCs, operating systems and web applications is a prerequisite. General knowledge in the field of automation technology is recommended.

Intended use

The HUB-VM102 was specifically developed for the industrial sector for the continuous vibration monitoring of machines and machine parts, such as bearings, shafts, springs and dampers, in order to detect both spontaneous failures and long-term wear.

The HUB-VM102 is not measuring equipment within the meaning of ISO 9001, and is therefore not subject to mandatory testing and the requirements for measuring equipment management.

in.hub products may only be used for the applications specified in the corresponding technical documentation.

If third-party products and components are used, they must be recommended or approved by in.hub.

Proper storage, set-up, assembly, installation, commissioning, operation and maintenance are essential for the correct and safe operation of the products.

The permissible ambient conditions must be complied with. Instructions in the associated documentation must be followed.

Brands

All designations marked with the “®” symbol are registered trademarks. The other designations in this document may be trademarks whose use by third parties for their own purposes may infringe the rights of the owner.

Disclaimer

in.hub accepts no liability for product malfunctions resulting from improper handling, mechanical damage, incorrect application and improper use.

The contents of this document have been checked for conformity with the product described. However, deviations cannot be ruled out, so that we cannot guarantee complete conformity. The information in this publication is regularly reviewed. Necessary corrections are included in subsequent editions.

1. General information

This document contains all the information you need to commission and use the device/software.

The document is intended for service technicians, system administrators and installers who connect the product with other units, configure it and commission it.

1.1. Scope of delivery

1 x HUB-VM102

1 x Operating Instructions as a PDF

If the HUB-VM102 is to be supplied with power via the backplane bus of a master gateway (e.g. HUB-GM200 or HUB-GM400), please note that you will need additional DIN-rail bus connectors. You can order these at in.hub as an option for your HUB-VM102. Please contact service@inhub.de for this.

1.2. Recommended accessories

- Vibration sensor, item number: A1000296
- DIN-rail bus connector (backplane connector)
Item number: A1000250

1.3. Other applicable documents

In addition to this document, please observe the following documents. You can find these in the in.hub download portal at <https://download.inhub.de>:

- User Manual for the IoT (Internet of Things) operating system SIINEOS
- Operating Instructions for other devices that you wish to plug in or connect
- Operating Instructions for the master gateway

1.4. Open source

A list of the open-source software used for the HUB-VM102 can be found in the download portal at <https://download.inhub.de/vm102>.

1.5. Disposal

Please observe the national regulations.

Do not dispose of the device with normal household waste, but appropriately for its nature and country-specific regulations, e.g. as waste electrical and electronic equipment (WEEE) or by commissioning a certified disposal company.

2. General product information

The HUB-VM102 module is specially designed for the detection of up to 2 parallel vibration signals. It is also possible to limit the measured frequency range using various digital filters. At the same time, instantaneous ADC values can be buffered in the internal RAM. These values can be used to perform a fast Fourier transform (FFT), for example.

The recorded and preprocessed data can be transferred to third-party systems via a network interface or directly to a gateway from in.hub for data visualization and further processing.

2.1. Intended use

The HUB-VM102 is ideal for:

- Long-term monitoring of conditions, generators, motors, gearboxes, turbines, pumps, fans, compressors, machines, bearings
- Vibration and impact testing, quality assurance and product testing

Highlights

- Continuous measurement of RMS values and peak values
- Instantaneous value storage and processing (FFT)
- Configurable filters (low pass, band pass, high pass)
- Monitoring functions in conjunction with a in.hub gateway: Data loggers, alarm messages when threshold values are exceeded
- Event-controlled measurement recording for data processing in the gateway through threshold value monitoring (RMS or peak value) and external digital pulses
- Sensor monitoring (cable break and short circuit)

2.2. Hardware – design and interfaces

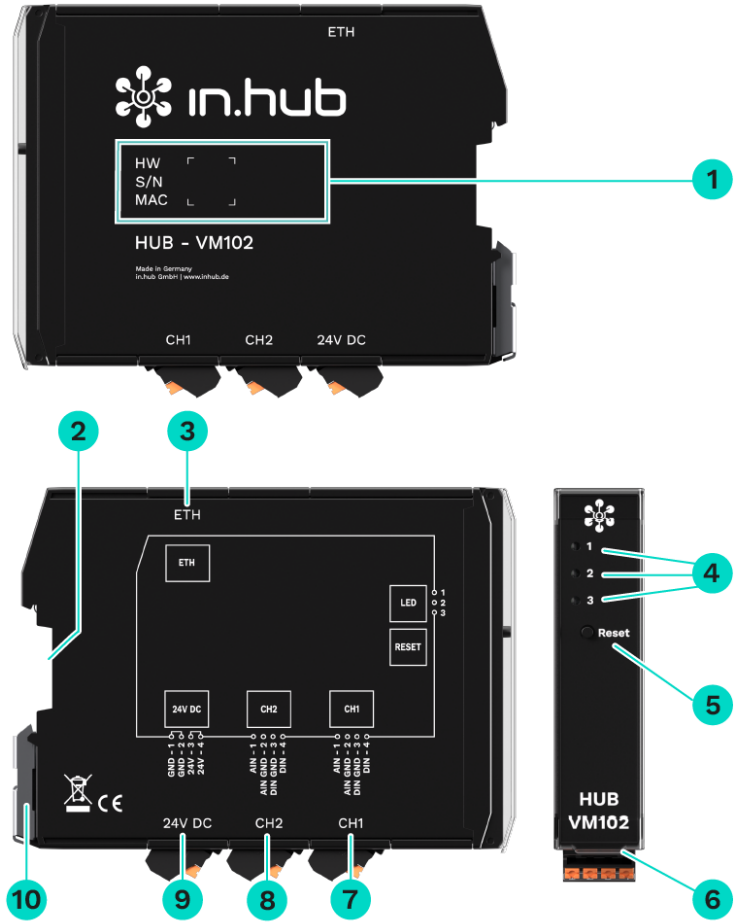

Views of the HUB-VM102 including interfaces

- 1 Device-specific information is stored in a barcode:
HW: Hardware revision
S/N: in.hub internal serial number
MAC: Hardware address of the Ethernet interface

- 2 Backplane bus

- 3 Ethernet (ETH)
Supports the MQTT and Modbus TCP protocols and is equipped with two LEDs.

- 4 LED status display

- 5 Reset button
Resets to the factory settings all parameter settings that you have carried out independently on the device.

- 6 Protective flap
Can be opened upwards.

- 7 Digital input / analogue input (CH1)

8	Digital input / analogue input (CH2)
9	24 V DC power supply
10	Clamping device for mounting on the DIN rail

2.2.1. Power supply

The module is supplied with power either by a 24 V power supply unit or via backplane bus of a master gateway. Please see the chapter [Installation \[13\]](#).

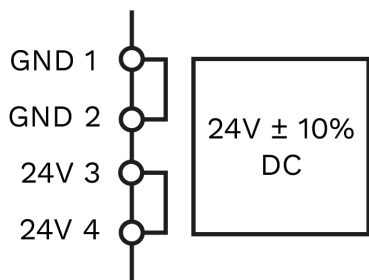

Connection assignment of the “power supply” interface

2.2.2. Pin assignment of the CH1 and CH2 interfaces

The technical parameters of the interfaces can be found in the chapter [Specification of the CH1 and CH2 interface \[25\]](#).

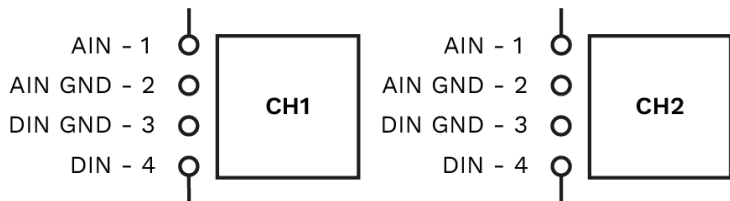

Pin assignment of interfaces CH1 and CH2		
1	AIN	Analogue input
2	AIN GND	Ground / 0 V
3	DIN GND	Ground / 0 V
4	DIO	Digital input

2.2.3. LED display

The three bicolour (red/green) LEDs on the front of the device indicate the following status:

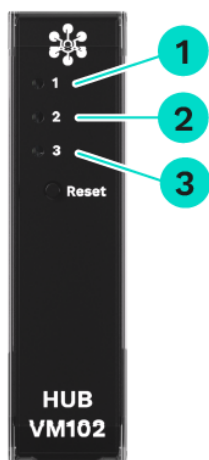

LEDs on the HUB-VM102

1	Device status
2	Status of IEPE interface 1 (CH1)
3	Status of IEPE interface 2 (CH2)

Behaviour of LED 1	Colour	Meaning
LED off	–	Device is out of order
Lights up briefly	Red	Backplane bus active
Flashing in heartbeat mode	Green	Module ready for operation
Flashing	Red	Maintenance mode (e.g. for FLASH updates or reset)

Behaviour of LEDs 2 and 3	Colour	Meaning
Permanently lit	Red	No sensor connected, sensor defective or cable defective (short or open circuit)
Permanently lit	Green	Sensor ready for operation

2.2.4. LED display on the ETH socket

The two single-colour LEDs (one green and one yellow LED) on the ETH interface can only be seen from above.

Colour	Meaning (function)
Green	Data transmission (link on)
Yellow	Network communication established (activity)

3. Assembly

The HUB-VM102 must be installed on a DIN EN 60715 (35 mm) mounting rail. Observe the applicable safety and accident prevention regulations for specific areas of application, such as the Machinery Directive.



CAUTION

Electric shock due to conductive dirt can cause personal injury!

- If possible, work with the power supply switched off.
- Avoid conductive contamination.
- Only install devices in a control cabinet with the appropriate protection class.



RECOMMENDATION

Maintain a minimum distance of 25 mm between the cable duct and the edge of the housing. This applies to both the top and bottom edges. This makes installation easier.

3.1. Mounting the device on the DIN rail

1. Make sure that the system's power supply is disconnected.
2. Turn the module so that the mounting foot (metal clamping device) is pointing downwards.
3. Hold the device at an angle to the DIN rail.
The recess on the back of the module is located above the mounting foot.
4. Click the module onto the DIN rail until you hear the mounting foot click into place.
5. After installation, check that the device sits firm and straight on the DIN rail.

3.2. Installation on a backplane bus

1. Make sure that the system's power supply is disconnected.
2. Make sure that the DIN-rail bus connector is attached to the master gateway or the previous module to which you want to connect the HUB-VM102.
3. Put another DIN-rail bus connector onto the DIN rail and push it along the DIN rail until directly next to the master gateway
4. Click the HUB-VM102 onto the DIN-rail bus connector you have just attached.



HUB-GM200 master gateway with a HUB-VM102

3.3. Dismantling the device

1. Make sure that the system's power supply is disconnected.
2. Use a screwdriver to pull the mounting foot (metal clamping device) downwards and remove the module from the DIN rail.



Removing the HUB-VM102 from the DIN rail

4. Installation

Read these instructions carefully and observe the safety instructions and warnings provided.

4.1. Connecting a power-supply unit

The HUB-VM102 requires its own power supply if it is NOT connected directly via the backplane bus as an extension of a master gateway. Whenever the HUB-VM102 is installed as an individual device or spatially separated from the master gateway, you must provide it with a separate power supply.



CAUTION

An incorrect power supply can cause irreparable material damage.

- Ensure that the power supply complies with the nominal voltage (of 24 V \pm 10%).

1. To make installation easier, you can remove the plug with the terminal contacts from the **24 V DC** interface.
2. Clamp the power connection cable into the plug. Observe the following schematic diagram when doing this:

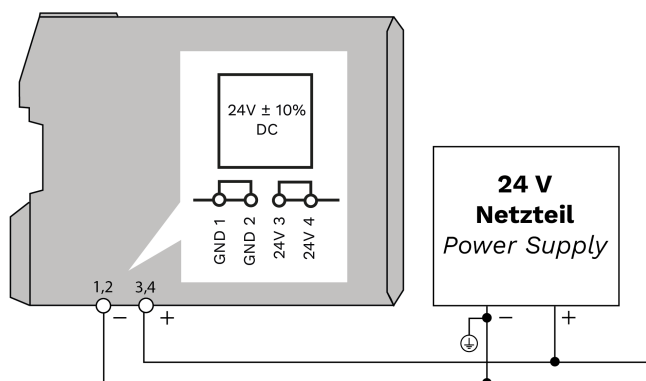

Schematic diagram of the power supply

A few seconds after the operating voltage is applied, the status LED starts to flash green.

4.2. Establishing a supply voltage via backplane bus

The backplane bus interface is only activated at the power-supplying master gateway and can supply up to 3 devices.

1. Mount up to three in.hub to the right of the master gateway on the backplane bus.
2. Log on to [SIINEOS on the master gateway](#) and navigate to **I/O management > I/O units**.
3. Navigate to the signals of the master gateway (e.g. of the HUB-GM200) and double-click on the **Backplane bus power supply** signal.

You should not rename this signal.

4. Set the **Enabled** slider to **On**.
By doing this, you activate the interface.
5. To activate the power supply, set the **Default state** to **On** under **Details**.
6. **Save & close**

4.3. Connecting vibration sensors



ATTENTION

These instructions refer to the connection of a PCB Piezotronics vibration sensor recommended by in.hub. If you connect a different vibration sensor, be sure to observe the technical details of the sensor used.

1. Switch off the power to the device.
2. Set the vibration sensor aside.
3. Connect the connecting cable to the HUB-VM102.
 - Take the two stripped cable ends.
 - Using a small screwdriver, first press down the orange actuator on pin **AIN** (number 1 on the connector) and insert the red connecting cable of the PCB vibration sensor. Release the orange actuator.
 - Repeat the procedure with the blue connecting cable and plug it into the **AIN GND** pin (number 2 on the connector).



Connecting a “PCB Piezotronic” vibration sensor to the HUB-VM102 (with wire-end ferrules in this example)

5. Further steps in the master gateway's SIINEOS

In the SIINEOS of the master gateway, configure the data communication with the HUB-VM102:

- Via network (LAN cable), see [Establishing communication with the HUB-VM102 via a network \[15\]](#)
- Via backplane bus, see [Establishing communication with the HUB-VM102 via a backplane bus \[19\]](#)

You can then process and visualise the signals from the vibration sensor(s) in Grafana, for example. These steps are described in the SIINEOS User Manual, which can be found in the download portal at: <https://download.inhub.de/siineos/>.

5.1. Establishing communication with the HUB-VM102 via a network

The procedure described here applies if you integrate a HUB-VM102 into your network using a LAN cable instead of a backplane bus. In this case, the master gateway and HUB-VM102 can be connected directly, or the HUB-VM102 can be connected to the corporate network via a LAN cable. Since the HUB-VM102 always uses the same IP address, it can be accessed from anywhere on the corporate network unless multiple devices are connected and their IP addresses are changed.

1. On the **I/O management** start page, select **I/O units**.
2. Click on **Add I/O unit**.
3. Select **HUB-VM102** as the type.

The setup wizard opens to guide you through the rule creation process. In the following, confirm each entry with **Next** or press **Enter**.

4. Enter the **Name** for the I/O unit.
5. Click on **Finish** to add the I/O unit.

A page will open where you can configure the settings for the unit.

Device settings for the HUB-VM102 in “Advanced” viewing mode (example)

The newly added I/O unit is automatically enabled. If you want to use it later, set the **Enabled** slider to **Off**.

6. Optional: Enter the **Location**.
7. If you want to use one HUB-VM102 on the network, enter the static IP address of the HUB-VM102: **192.168.1.200**.
– or –
8. If you want to use more than one HUB-VM102 on the network, a different IP address must be assigned to each device. To do this, complete the following steps for each HUB-VM102.
 - a. Connect to the HUB-VM102 whose IP address you wish to change.
 - b. Open the device settings for the other I/O unit of type HUB-VM102.
 - c. Switch to **Advanced** viewing mode.
 - d. Click on the **Change VM102 network settings** button.

- e. Enter a **New IP address**, a **New network mask** and a **New gateway address** and confirm with **OK**.

This setting is made directly in the HUB-VM102. The device now has the newly assigned IP address and can be accessed via this address on the network. Take care to assign the IP address only once.

- f. In the **Request timeout [ms]** field, define after how many milliseconds without a response a request should be resent or discarded.
 - g. In the **Request retry count** field, enter how often a request should be sent if no response is received. After the entered number of attempts, the request is finally cancelled.
9. Click on **Signals**.

The signals for all channels of the HUB-VM102 have already been created.

I/O management > I/O units > HUB-VM102 in.hub Fabrik > Signals

<input type="checkbox"/>	Identifier ^	Name	Group	Type	Value
<input type="checkbox"/>	FREQ_DIN1	Digital Input 1 Frequency		DOUBLE	0,0 Hz
<input type="checkbox"/>	FREQ_DIN2	Digital Input 2 Frequency		DOUBLE	0,0 Hz
<input type="checkbox"/>	PEAK_S1	Sensor 1 Peak		DOUBLE	0,0 m/s ²
<input type="checkbox"/>	PEAK_S2	Sensor 2 Peak		DOUBLE	0,0 m/s ²
<input type="checkbox"/>	RMS_S1	Sensor 1 RMS		DOUBLE	0,0 m/s ²
<input type="checkbox"/>	RMS_S2	Sensor 2 RMS		DOUBLE	0,0 m/s ²
<input type="checkbox"/>	VOLT_S1	Sensor 1 Voltage		DOUBLE	0,0 V
<input type="checkbox"/>	VOLT_S2	Sensor 2 Voltage		DOUBLE	0,0 V

Signals for the HUB-VM102 (example)

10. Select the signal you want to configure.
- A window opens in which you will find three tabs.

I/O management > I/O units > HUB-VM102 in.hub Fabrik > Signals > Digital Input 1 Frequency

SIGNAL SETTINGS SIGNAL PROCESSING MEASUREMENT MODELLING

General

Name
Digital Input 1 Frequency

System ID
freq_din1

Enabled
 On

Record signal values
 On

Use custom identifier
 Off

Sampling interval [ms]
- 1000 +

Recording interval [s]
- 60 +

Custom identifier
FREQ_DIN1

“Signal settings” tab in “Advanced” viewing mode

11. Enable and configure the interface on the **Signal settings** tab.
- a. Optional: Change the name of the interface.
 - b. Set the **Enabled** slider to **On**.
 - c. In the **Sampling interval** field, specify the interval at which the signal is to be sampled (in milliseconds).
 - d. Set the **Record signal values** slider to **On** if the values are to be recorded in the local VictoriaMetrics database.
 - e. In the **Recording interval** field, enter the desired time interval for the recording (in seconds).
12. Additional settings are available in **Advanced** viewing mode:
- a. **Use custom identifiers:** Set the slider to **On** if you want to enter your own identifier name.
 - b. **Custom identifier:** Enter your own identifier name.

13. On the **Signal processing** tab, you can specify how the signal value is to be processed. You can find out more at [Configuring the signal processing steps](#).
14. Click on **Save**.
15. On the **Measurement modelling** tab, you specify how the measurements are to be visualized. You can find out more at [Measurement modelling](#).
16. Finally, click on **Save & close**.

5.2. Establishing communication with the HUB-VM102 via a backplane bus

If you want to connect a HUB-VM102 via the backplane bus of a master gateway, you must complete the following steps:

- Have the device mounted to the right of the master gateway, see [Installing additional modules on the master gateway](#).
 - Activate the power supply of the backplane bus interface of the master gateway, see [Establishing a supply voltage via backplane bus \[13\]](#).
 - Enable data communication by creating and configuring a Modbus RTU client in the master gateway, see the following steps in this chapter.
 - Download the setup file for Modbus RTU in JSON format from the download portal: <https://download.inhub.de/vm102/>. This saves you work when creating the signals.
1. Log on to [SIINEOS on the master gateway](#) and navigate to **I/O management > I/O units**.
 2. Create a new **Modbus client** I/O unit and select the Modbus type **Modbus RTU**.
 3. Click **Actions > Load settings from file** and select the downloaded JSON file.
All necessary settings are filled in automatically and all signals from the HUB-VM102 are imported.

The screenshot displays the configuration page for a Modbus RTU client in the SIINEOS interface. The breadcrumb navigation shows 'I/O management > I/O units > Modbus RTU'. The page is divided into two main sections: 'General' and 'Modbus client'.

General section:

- Enabled:** A toggle switch is turned 'On'.
- System ID:** 700832793854494d8e9b4bf72407679d
- Name:** Modbus RTU
- Location:** e.g. Building 1, Room 234

Modbus client section:

- Modbus type:** Modbus RTU (selected in a dropdown)
- Modbus ID:** 1 (input field with a '+' sign)
- Bus interface:** Serial port (selected in a dropdown)
- Baud rate:** 115200 (selected in a dropdown)
- Data bits:** 8 (selected in a dropdown)
- Parity:** No parity (selected in a dropdown)
- Stop bits:** 1 (selected in a dropdown)
- Request timeout [ms]:** 100 (input field with '-' and '+' signs)
- Request retry count:** 0 (input field with '-' and '+' signs)
- Request queue size limit:** 100 (input field with '-' and '+' signs)
- Delay between messages [ms]:** -1 (input field with '-' and '+' signs)

At the bottom of the 'Modbus client' section, there is a button labeled 'IMPORT MODBUS DEVICE PROFILE'.

Modbus RTU settings in the SIINEOS of the master gateway

4. Under **Modbus ID**, enter the backplane bus ID, which is made up of the last three digits of the serial number of the HUB-VM102.

The range defined by in.hub for the Modbus ID is between 1 and 100. Therefore, an ID cannot be 0 and cannot be greater than 100.

Example: The serial number is **13197240900021**. The backplane bus ID would be **21**.

5. Click on **Save**.

Data communication is now established.

NOTE: You can see whether data communication has been successfully established under **I/O units**. The corresponding tile of the I/O unit has a turquoise-coloured stripe on the upper frame.



NOTE

For each additional HUB-VM102 (up to 3 devices on one master gateway), you must create your own Modbus RTU client and always derive the Modbus ID from the respective device serial number located on the housing.

6. Typical use cases in practice

The following chapter explains the typical application options for a HUB-VM102.

Find out in which different scenarios the device can be used and which basic tasks are necessary to work with the HUB-VM102. For detailed step-by-step instructions, please refer to the relevant sections in this documentation and the SIINEOS User Manual.

6.1. Communication via a network and data transfer to a master gateway or third-party system

CASE 1: One or more HUB-VM102s are individually installed, have their own power supplies and are connected via a LAN cable to a in.hub master gateway, such as the HUB-GM200. The master gateway collects the data from the connected vibration sensors and processes and visualizes this data itself. SIINEOS and Grafana are available for this purpose. Alternatively, the data is – in turn – collected from the master gateway by a higher-level system, which processes and visualizes the data in its own program.



TIP

The HUB-VM102 should be combined with a master gateway if, for example, you require more comprehensive signal-processing and data-visualization features for the measured sensor data.

The combination of master gateway and HUB-VM102 allows a holistic view of the machinery and systems and a wide range of use cases, as a whole range of further data can be collected and processed via the master gateway.



1. Install one device or more on the DIN rail in the control cabinet.
2. Attach a power supply unit to each device to establish the power supply.
3. Connect the vibration sensors – max. 2 current sensors on each device.
4. Make sure that the HUB-VM102 is accessible in the network.
5. In the master gateway's SIINEOS, add a **HUB-VM102** I/O unit in **I/O management**. In I/O management, you also configure the signals, as well as signal processing and measurement modelling.

If you want to use more than one device in the network, you must change the IP address(-es) of the other devices.

6. You can now visualize the data of the vibration sensors in **Grafana** (login with **admin/admin**) and create your own dashboards;
 - or –
 - if you want to transfer the data to a third-party system, set up an OPC-UA connection.

6.2. Communication via network and data transfer to PLC or PC

CASE 2: One or more HUB-VM102s are individually installed, have their own power supplies and are connected to a (corporate internal) network via a LAN cable. A PLC or PC collects the data from the HUB-VM102, where it is processed and visualized using the applications there.

Multiple devices from various locations can also transmit data to the master gateway via the network.

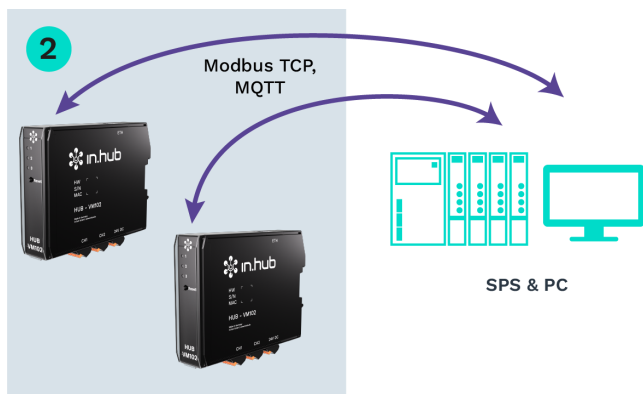

1. Install one device or more on the DIN rail in the control cabinet.
2. Attach a power supply unit to each device to establish the power supply.
3. Connect the vibration sensors – max. 2 current sensors on each device.
4. Make sure that the HUB-VM102 is accessible on the network.
5. To program data collection from the HUB-VM102, please use the Programming Manual of the HUB-VM102. You can find this in the download portal at <https://download.in-hub.de/vm102/>.

6.3. Communication via backplane bus and data transfer to a master gateway or third-party system

CASE 3: One or more HUB-VM102s are connected to a in.hub master gateway, such as the HUB-GM200, via the backplane bus and also draw their power supply through this connection. The master gateway collects the data from the vibration sensors via the backplane bus, where it is processed and visualized. SIINEOS and Grafana are available for this purpose. Or a higher-level system in turn collects the data from the master gateway and processes and visualizes it in its own program.

Up to 3 devices can be connected to the master gateway via backplane bus.



1. Install one device or more on the backplane bus of the master gateway, which is already located on the DIN rail in the control cabinet.
2. Connect the vibration sensors – max. 2 current sensors on each device.
3. In the SIINEOS of the master gateway in the **I/O management** activate the **Backplane bus power supply** signal.
4. For data communication, now add a **Modbus client** I/O unit. To do this, use the Modbus RTU setup file in JSON format, which you can download from the download portal.
5. Under **Modbus ID**, enter the backplane bus ID, which is made up of the last three digits of the serial number of the HUB-VM102.

The range defined by in.hub for the Modbus ID is between 1 and 100. Therefore, an ID cannot be 0 and cannot be greater than 100.

Example: The serial number is **13197240900021**. The backplane bus ID would be **21**.

Data communication is now established. You have to create another Modbus RTU client for each additional HUB-VM102.

6. If you want to process the data in the master gateway, open the **Grafana** app, log in (with **admin/admin**) and create your own dashboard in which you can visualize the desired signals;

– or –

if you want to transfer the data to a third-party system, set up an OPC-UA connection.

7. Technical data

Data	
Power supply	24 V DC \pm 10 %
Current consumption	~130 mA
Microcontroller	166 MHz, 32 Bit ARM Cortex M7
Storage	16 MB
Data interfaces	Ethernet: 100 Mbit/s 3 x status LEDs Backplane bus
Connections for peripheral devices	2 x analogue input for IEPE vibration and acoustic sensors 2 x digital input (max. 30 V and max. 10 kHz)
Protocols	MQTT client Modbus TCP/IP server
Housing	Plastic (polyamide) black, flammability class UL 94 V0
Protection class	IP20
Dimensions	139 mm \times 100 mm \times 25 mm
Weight	142 g

Ambient conditions	
Temperature range	Storage: -40°C to 85°C Operation: 0°C to 50°C
Humidity	Storage: 10% to 95% RH, non-condensing Operation: 20% to 90% RH, non-condensing
Operating altitude	Max. 2,000 m above sea level

7.1. Specification of the CH1 and CH2 interface

Digital input DIN	
Switching threshold	between 1 V and 12 V (2.5 V default) 0.5 V hysteresis
Input resistance	1 MΩ
Bandwidth	10 kHz
Permissible input voltage range	-3 to 30 V

Analogue input AIN	
Function	Connection for IEPE-compliant sensors for vibration monitoring
Connection	One IEPE sensor per channel; data can be recorded synchronously
Power supply for IEPE sensors	~4 mA and monitoring of the IEPE voltage
Maximum AC input level	6 V _{eff}
IEPE channel bandwidth	0.5 Hz to 10 kHz
ADC sampling frequency	48 kHz
ADC resolution	24 bit

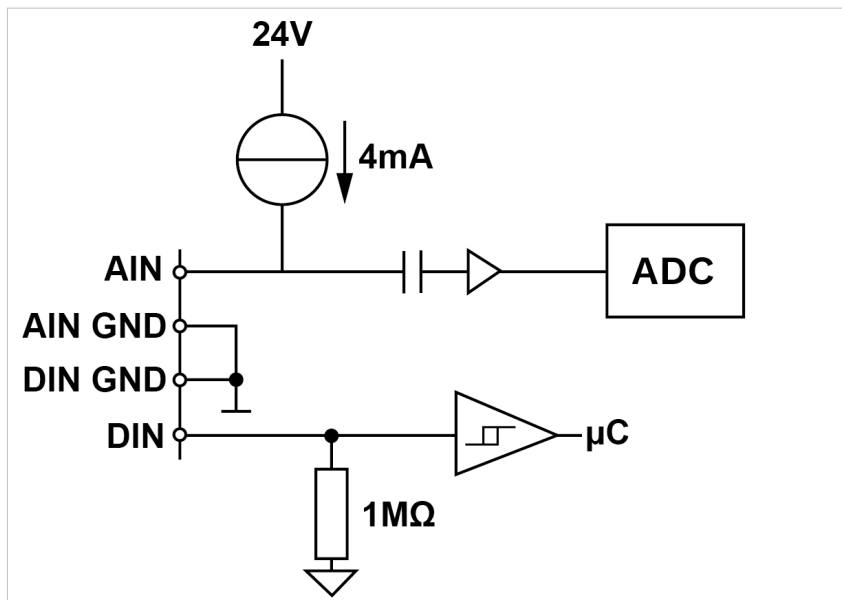

Circuit diagram of the CH interface (CH1 and CH2 are identical)

7.2. Backplane bus specification

Backplane bus	
Voltage on the backplane bus	Voltage of the power supply unit minus 0.5 V Switchable in the signals of the master gateway
Communication	Modbus RTU
Max. number of additional modules on one master gateway	3

This document is available in electronic form in the download portal of in.hub. Printed versions or copies not explicitly provided by in.hub are deemed uncontrolled.

The original language of this document is German.

Made in Germany.

Service & Support: service@inhub.de | <https://community.inhub.de>

in.hub Download portal: <https://download.inhub.de>



in.hub GmbH
Technologie-Campus 1
DE-09126 Chemnitz

+49 371 335 655 00
info@inhub.de