

# HUB-RTU

## Operating Instructions

Document version 1.0 | Publication date:  
14. April 2026

---

# Table of Contents

- Legal information ..... 3**
- 1. General information ..... 5**
  - 1.1. Scope of delivery ..... 5
  - 1.2. Recommended accessories ..... 5
  - 1.3. Other applicable documents ..... 5
  - 1.4. Disposal ..... 5
- 2. General product information ..... 6**
  - 2.1. Intended use ..... 6
  - 2.2. Hardware – design and interfaces ..... 7
- 3. Assembly ..... 8**
  - 3.1. Mounting and removing the device on/from the DIN rail ..... 8
- 4. Installation ..... 10**
  - 4.1. Connecting the supply voltage ..... 10
  - 4.2. Connecting the HUB-RTU ..... 10
  - 4.3. Connecting RTU devices to the HUB-RTU ..... 11
- 5. Setting up data communication for RTU devices ..... 13**
- 6. Technical data ..... 14**
  - 6.1. Schematic diagram ..... 15

## Legal information

### Safety information

This documentation contains information that you must observe for your personal safety and to prevent material damage. Read the safety information carefully and always keep this documentation within easy reach.

The safety information is presented in descending order of hazard level as follows:

**DANGER**

Indicates an immediate hazard to humans. Failure to comply will lead to irreversible injuries or death.

**WARNING**

Indicates an identifiable hazard to humans. Failure to comply may lead to irreversible injuries or death.

**CAUTION**

Indicates an identifiable hazard to humans or potential material damage. Failure to comply may lead to reversible injuries or material damage.

**ATTENTION**

This gives you information that may lead to material damage if not complied with.

**NOTE**

A note gives you useful information on specific actions and issues.

**TIP**

A tip gives you tips, tricks or recommendations from in.hub that have proven to be helpful in handling the products.

### Qualified personnel

The product associated with this documentation may only be handled by personnel qualified for the respective task. The device may only be installed, commissioned and operated in compliance with the associated documentation and the safety information contained therein.

Based on their training and experience, qualified personnel are able to recognize risks and avoid potential hazards when handling these products.

Knowledge of PCs, operating systems and web applications is a prerequisite. General knowledge in the field of automation technology is recommended.

## Intended use

The HUB-RTU is intended exclusively for use in the industrial sector. It serves as an interface module and facilitates installation, enabling multiple Modbus RTU devices to be connected to a gateway quickly.

in.hub products may only be used for the applications specified in the corresponding technical documentation.

If third-party products and components are used, they must be recommended or approved by in.hub.

Proper storage, set-up, assembly, installation, commissioning, operation and maintenance are essential for the correct and safe operation of the products.

The permissible ambient conditions must be complied with. Instructions in the associated documentation must be followed.

## Brands

All designations marked with the “®” symbol are registered trademarks. The other designations in this document may be trademarks whose use by third parties for their own purposes may infringe the rights of the owner.

## Disclaimer

in.hub accepts no liability for product malfunctions resulting from improper handling, mechanical damage, incorrect application and improper use.

The contents of this document have been checked for conformity with the product described. However, deviations cannot be ruled out, so that we cannot guarantee complete conformity. The information in this publication is regularly reviewed. Necessary corrections are included in subsequent editions.

## 1. General information

This document contains all the information you need to commission and use the device/software.

The document is intended for service technicians, system administrators and installers who connect the product with other units, configure it and commission it.

### 1.1. Scope of delivery

1 x HUB-RTU

1 x Operating Instructions as a PDF

### 1.2. Recommended accessories

- Network cable, 0.25 m, for direct cabling next to a master gateway or for a direct connection to the next

Item number: A5000054

### 1.3. Other applicable documents

In addition to this document, please observe the following documents. You can find these in the in.hub download portal at <https://download.inhub.de>:

- Operating Instructions for other devices that you wish to plug in or connect

### 1.4. Disposal

Please observe the national regulations.

Do not dispose of the device with normal household waste, but appropriately for its nature and country-specific regulations, e.g. as waste electrical and electronic equipment (WEEE) or by commissioning a certified disposal company.

## 2. General product information

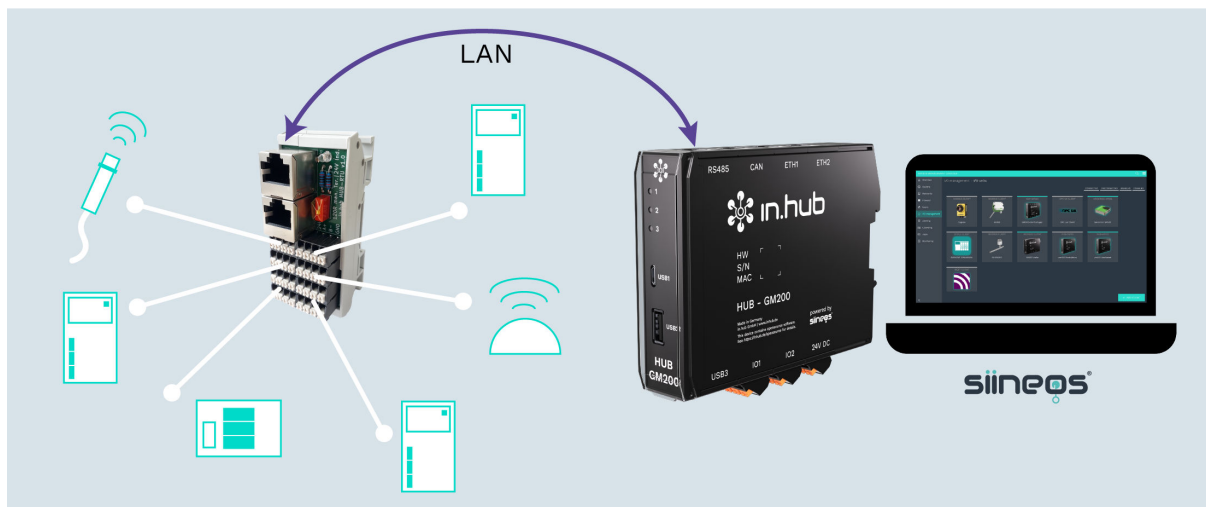

The HUB-RTU serves as an interface module and facilitates installation, enabling multiple Modbus RTU devices to be connected to a gateway quickly and easily. It is designed for use in a control cabinet and can be mounted directly next to a gateway.

### 2.1. Intended use

The HUB-RTU is ideal if you have installed – or plan to install – a large number of Modbus RTU devices and there is not enough space at the HUB-GM200 master gateway to connect them all directly.

## 2.2. Hardware – design and interfaces

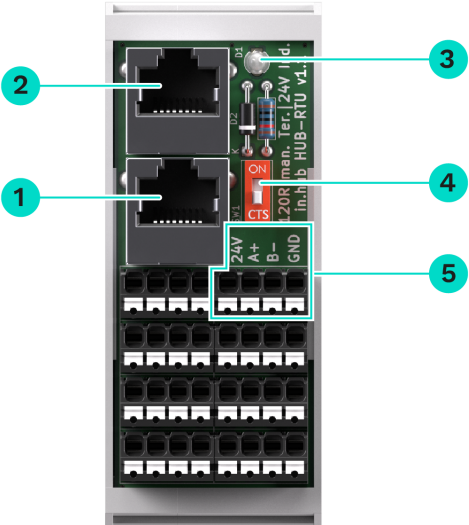

1/2	RS485 interface for LAN cable For connection to a in.hub module and another HUB-RTU
3	LED to indicate the status of the 24 V power supply provided by the in.hub module
4	120 ohm terminating resistor
5	8 x terminals per HUB-RTU for connecting up to 8 Modbus RTU devices

## 3. Assembly

The HUB-RTU must be installed on a DIN EN 60715 (35 mm) mounting rail. Observe the applicable safety and accident prevention regulations for specific areas of application, such as the Machinery Directive.



### CAUTION

Electric shock due to conductive dirt can cause personal injury!

- If possible, work with the power supply switched off.
- Avoid conductive contamination.
- Only install devices in a control cabinet with the appropriate protection class.



### RECOMMENDATION

Maintain a minimum distance of 25 mm between the cable duct and the edge of the housing. This applies to both the top and bottom edges. This makes installation easier.

### 3.1. Mounting and removing the device on/from the DIN rail

1. Make sure that the system's power supply is disconnected.
2. Turn the device so that the RS485 interfaces are located at the top left.
3. Working from above, position the device at an angle against the DIN rail and press it down and back until it audibly clicks into place.



Mounting the HUB-RTU

4. After mounting, check that the device is securely seated and aligned straight on the DIN rail.
5. To remove the device, use a screwdriver to press one of the two grey plastic feet back until the HUB-RTU detaches from the DIN rail on that side. Then repeat this step on the other plastic foot.

**TIP:** While releasing the second plastic foot, hold the device firmly to prevent it from falling.

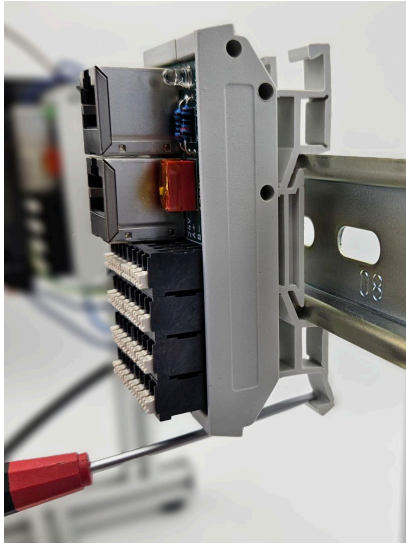

Removing the HUB-RTU

## 4. Installation

Read these instructions carefully and observe the safety instructions and warnings provided.

**NOTE**

The HUB-RTU can only be connected to gateways of type HUB-GM200 and above.

**NOTE**

Cable lengths of up to 50 m are possible. However, please note the cable length may have to be reduced in the event of adverse ambient conditions, a high baud rate or a large number of connected devices.

### 4.1. Connecting the supply voltage

The HUB-RTU is supplied with power as soon as it is connected to the master gateway via the RS485 interface.

**ATTENTION**

The RS485 bus can provide a power supply of up to 0.75 A in total. If you require more power because you have connected a large number of devices to the HUB-RTU, please use an external power supply.

### 4.2. Connecting the HUB-RTU

1. Switch off the power to the in.hub master gateway.
2. Use a network cable to connect the gateway and the HUB-RTU.  
To do this, plug the network cable into the RS485 socket on the gateway and into one of the two RS485 sockets on the HUB-RTU:



Example: Two HUB-RTU devices connected to one HUB-GM200

3. If you wish to connect another HUB-RTU device, you can simply connect it to the previous one using another network cable between the relevant RS485 sockets.



#### ATTENTION

The RS485 bus can provide a power supply of up to 0.75 A in total. If you require more power because you have connected a large number of devices to the HUB-RTU, please use an external power supply.

### 4.3. Connecting RTU devices to the HUB-RTU

1. Switch off the power to the gateway and the HUB-RTU.
2. Have the RTU device ready.
3. Take the stripped ends of the RTU device cable and connect them to the HUB-RTU in accordance with the markings:

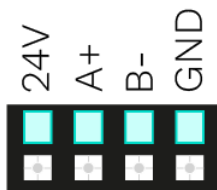

Pin configuration of the terminals on the HUB-RTU



## 5. Setting up data communication for RTU devices

1. Please refer to the SIINEOS User Manual.  
You can find the current document at <https://download.inhub.de/siineos/>.
2. In the SIINEOS system on the master gateway, create a new **I/O unit** of type **Modbus client** under **I/O management** for each connected RTU device. To do this, follow the step-by-step instructions in the chapter “*Adding a Modbus client of type RTU*”.
3. Please note that each RTU device has its own Modbus ID. It is best to have the data sheets for the RTU devices to hand so that you can enter all the parameters in SIINEOS.

## 6. Technical data

<b>Data</b>	
Compatibility with gateway	HUB-GM200 and above
Power supply	24 V DC $\pm$ 10 %
Data interfaces	2 x RS485 1 x status LED (green)
Connections	8 x terminals for up to 8 Modbus RTU devices
Protection class	IP20
Dimensions	34 mm $\times$ 82 mm $\times$ 43 mm
Weight	60 g
Mounting	DIN rail

<b>Terminal specifications</b>	
Terminal assignment	24 V A+ B- GND
Clamping range	0.2 – 1.5 mm <sup>2</sup>

<b>Ambient conditions</b>	
Temperature range	Storage: $-40^{\circ}\text{C}$ to $85^{\circ}\text{C}$ Operation: $0^{\circ}\text{C}$ to $50^{\circ}\text{C}$
Humidity	Storage: 10% to 95% RH, non-condensing Operation: 20% to 90% RH, non-condensing
Operating altitude	Max. 2,000 m above sea level

## 6.1. Schematic diagram

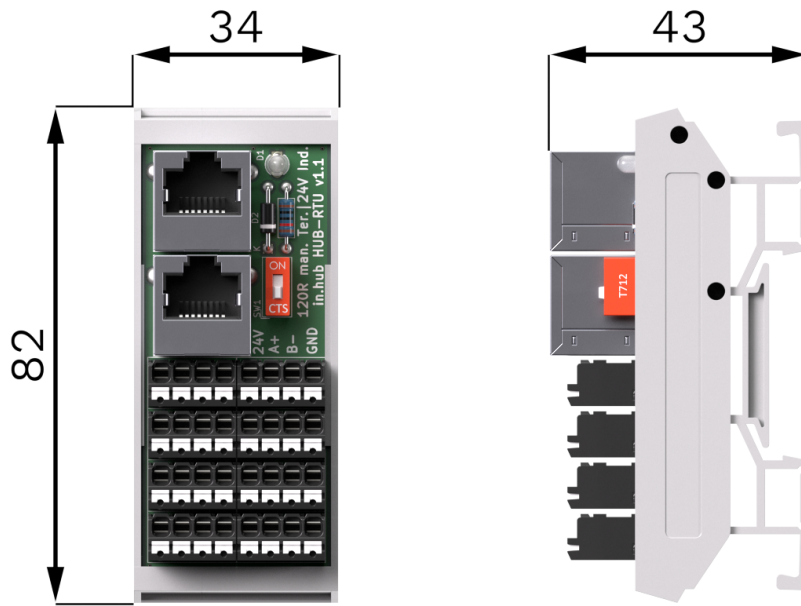

Dimensions of the HUB-RTU in mm

This document is available in electronic form in the download portal of in.hub. Printed versions or copies not explicitly provided by in.hub are deemed uncontrolled.

The original language of this document is German.

Made in Germany.

Service & Support: [service@inhub.de](mailto:service@inhub.de) | <https://community.inhub.de>

in.hub Download portal: <https://download.inhub.de>



**in.hub GmbH**  
**Technologie-Campus 1**  
**DE-09126 Chemnitz**

**+49 371 335 655 00**  
**info@inhub.de**